



**Installation Manual
Harley Touring Bikes
2009 - UP
Version 3**

**Copyright 2011, Pete Giarrusso, Inc.
D/B/A Chopper Design Services
All Rights Reserved**

Table of Contents

INTRODUCTION	4
WARRANTY	5
INSTALLATION INSTRUCTIONS	6
COMPONENTS:	6
1) <i>Control Switch Box</i>	6
2) <i>Linear Actuator</i>	6
3) <i>On-board Computer Module</i>	6
4) <i>Proximity Sensor</i>	6
5) <i>Leg Support Stand</i>	6
6) <i>Leg/Wheel System</i>	6
7) <i>Hardware Bag</i>	6
8) <i>Actuator Bracket</i>	6
PREPARE FOR INSTALLATION	7
INSTALL LEG SUPPORT STAND	8
ACTUATOR BRACKET	10
LEG/WHEEL ASSEMBLY	11
MOUNT ACTUATOR	12
CONTROL SWITCH BOX	13
WIRING HARNESS	14
INITIAL SYSTEM TEST	16
MOUNT PROXIMITY SWITCH	17
WIRE ROUTING	18
FINISHING UP	19
<i>ACTUATOR ADJUSTMENT (Maintenance Mode)</i>	19
TEST RIDE	21
LEGUP LITE - ADDENDUM	23
ILLUSTRATIONS	24
<i>Wiring 1</i>	24
<i>Wiring 2</i>	24
<i>Wiring 3</i>	25
PARTS LIST	26

Introduction

This manual covers installation of the LegUp Landinggear system by Chopper Design Services. This system should only be installed by a qualified technician, or those with above average mechanical skills. If you are not SURE that you can perform this installation, please contact us and we will help you find a qualified shop to assist you.

If you have been looking for a system that will keep your feet on the pegs, this is NOT the system for you! On the other hand, if a system that will relieve you of the weight of the bike and help you avoid balance problems as you approach a stop, LegUp is what you need.

Improper installation will void your warranty, so please be very careful!

Thanks for choosing LegUp!

Warranty

Chopper Design Services warrants the LegUp system for a period of one year from date of purchase. This warranty covers replacement parts and/or manufacturer defects. Incidental damages or costs are the responsibility of the purchaser.

Defective parts are to be returned to Chopper Design at the address below. Purchaser must contact Chopper Design to receive a Return Material Authorization, prior to returning defective parts to Chopper Design.

Abuse, improper installation or use, collisions or accidents, are not covered under this warranty. Replacement parts for this type of damage are available through Chopper Design.

Users of the LegUp system agree that Chopper Design is NOT responsible for personal injuries or damage to property arising from the use of the system. While we believe this system to be safe and reliable, the user is advised that use of LegUp is done so at the users' own risk. Use of the system implies agreement to the above statements. If you can't agree with the above, Chopper Design and its dealers would be happy to refund your full purchase price, before you use the LegUp System.

Chopper Design Services
1365 Bennett Dr #101
Longwood, FL 32750

407-834-5007
LegUp@LandinGear.com

Installation Instructions

The LegUp® system has many components. Please be sure you have them all before starting your installation.

COMPONENTS:

- 1) **Control Switch Box**
- 2) **Linear Actuator**
- 3) **On-board Computer Module**
- 4) **Proximity Sensor**
- 5) **Leg Support Stand**
- 6) **Leg/Wheel System**
- 7) **Hardware Bag**
- 8) **Actuator Bracket**

If you believe you are missing any parts, please contact Chopper Design at 407-834-5007, and we will rectify the situation.

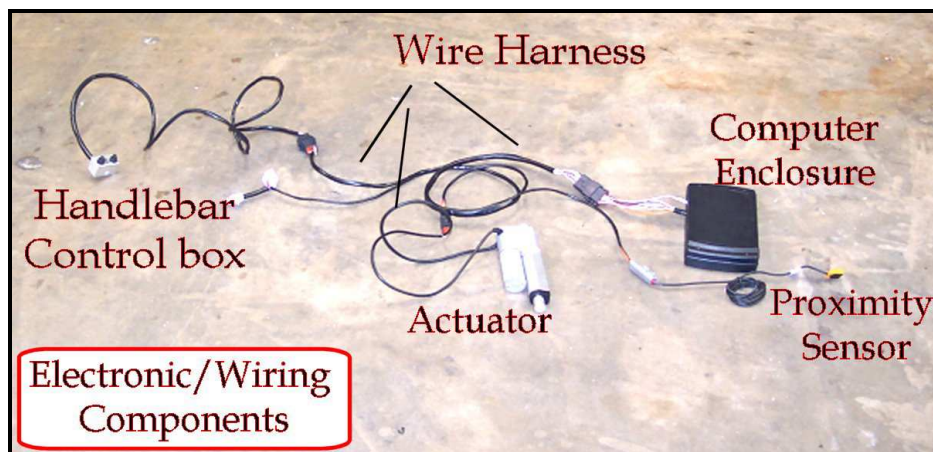

Figure 1

PREPARE FOR INSTALLATION

NOTES on 2009 AND LATER BIKES:

2009 and later Harley-Davidson touring bikes MUST use a 2 into 1 Exhaust on the right side of the bike! We recommend the Freedom Performance Union exhaust (website below). While other exhausts may work, we can't know if you will get the full height of the wheels or the clearance required with any other exhaust system.

http://freedomperform.com/shop/?page_id=3&category=3&product_id=170

Place the motorcycle on an acceptable bike lift. You will need to keep the bike on its wheels for most of the installation, and jack the rear wheel off the lift for some portion of the installation. Make SURE the motorcycle is secure on the lift!

Remove the seat, saddlebags and side covers, they are not needed until the very end of the installation.

We are now ready to begin!

INSTALL LEG SUPPORT STAND

LegUp has developed a new, stronger attachment system which replaces the Harley-Davidson® center stand previously included in the kit! If you already have a 2 into 1 exhaust, remove or loosen it, otherwise take off your existing exhaust as you will need to install such an exhaust. Remove the right front floorboard and the left rear floorboard. These need to be removed to allow access to the swing arm pillow block lower bolts, which attach the support stand to the motorcycle.

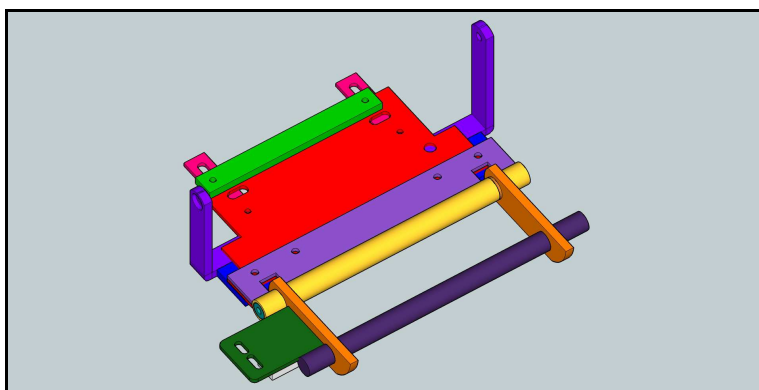

Leg Support Stand

We install this stand by attaching front and rear supports then sliding the plate in place. We start by finding the uprights (left and right, ninety degree brackets with plates attached). The taller upright goes on the right side of the bike (the far side in this picture). Remove the bottom bolts from the swing arm pillow blocks and set them aside. The right one may have a cap rather than a bolt. These bolts are the ones under the big chrome circles where the swing arm meets the frame. Install a supplied chrome bolt in each Upright (left one shown here) and leave the upright hanging. Do not tighten yet!! Do the same on the other side of the bike. Use some Loctite on these and all the bolts you install on the bike!

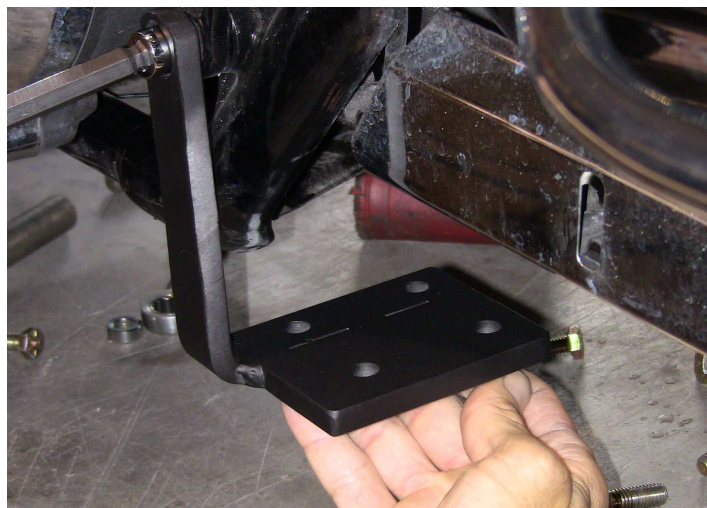

Find the 3/8" Strap (green above) and the (2) Front Support Straps (3/16" steel, 4.25" long, with a small hole and a slot in them), (2) 5/16" bolts and lock washers, and 2 Chrome spacers. Place the strap above the cross-brace that is under the transmission; it should fit right in and slide a bit back and forth once placed. Take a bolt, then a lock washer, then a flat washer, run it through the slotted side of one of the Support Plates, then the spacer, through the hole in the frame into the threaded hole in the strap you just placed under the transmission. This can be tricky; move the plate around as needed to find the threads! Do not tighten yet!



Here is a picture of the mounting of this Support Strap (fuzzy...sorry!). Do the same on the other side of the bike. Leave both straps dangling for now.

We should now have two straps and two uprights hanging from the bottom of the bike.

The next step is to slide the large flat plate with the pipe on one end under the rear uprights. This gets installed with the pipe toward the rear of the bike and the offset of the pipe up (the bottom of

the plate should be completely flat). Once the plate is in place, find four 3/8" bolts and lock washers and start these bolts through the uprights, into the threaded holes in the rear of the plate. Keep these very loose for now.

Next find two short 5/16" bolts with lock washers. These bolts will go through the small hole in the Support Straps installed earlier. Rotate the straps toward the back, install the bolt, then lock washer through the strap, and find the threaded holes on each side of the plate, and start the bolts into the plate.

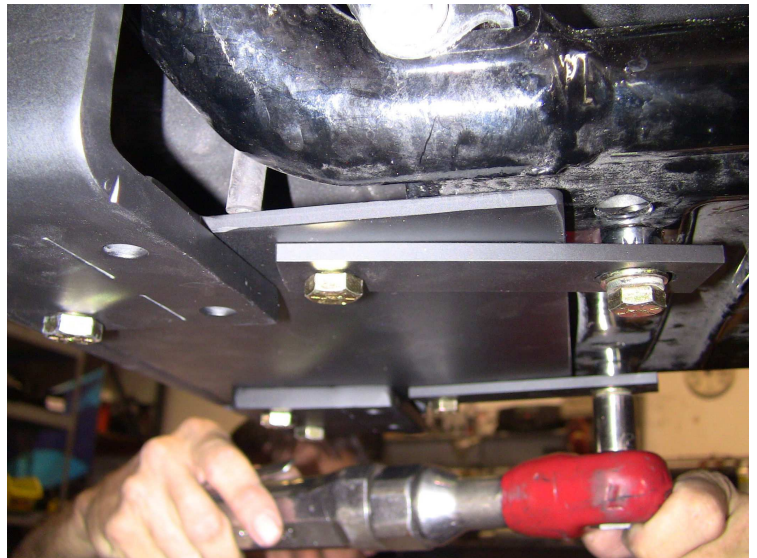

The picture at right shows all the bolts installed. There is a specific tightening sequence to follow here. Make sure the uprights are exactly vertical, then tighten the 4 rear bolts first, then tighten the two you just threaded into the plate, then the two in the front that go through the cross-member and finally the chrome pillow block bolts last!

Take your time and make sure it is secure and the uprights remain vertical. Once you are happy with this, you should double check all of the bolts! This Plate should be very secure to the bike; give it a tug. It should be one with the motorcycle!

Once the support stand is installed, we can move onto the installation of the actuator bracket. **DO NOT** Reinstall the Exhaust System or Floorboard Yet!

ACTUATOR BRACKET

The actuator bracket mounts to the vehicle using the bolt that holds the left saddlebag/crash bar to the bike. Remove this bolt and nut and slide the actuator bracket between the mount on the frame and the saddlebag support as shown to the right.

Install the Chrome Allen (7/16X1.5") bolt through the mount then the actuator bracket and install the matching Nylock nut behind it. This bracket should fit very tightly up against the slanted frame rails; it should be difficult to install the bolt. It is this tight fit that keeps this bracket from rotating under load. If need be, we can shim this bracket; it can't rotate. Make sure you tighten it securely! **Note: IF the fit is too tight, you can use the stock nut and bolt, but again, make sure the bracket does not rotate!**



Once installed, there are two things you need to check. Clearances are very tight here!

The aluminum bracket must not touch the saddlebag bracket. Verify this is the case. If it DOES touch and the other clearances are fine, you can grind/file the corner of this aluminum bracket a bit without hurting it.

The other worry would be that this

same bracket has clearance from the swing-arm. We don't need much room (as you can see in the picture at right!), but it can't rub the swing-arm!

If it interferes in any way, you can remove the entire actuator bracket, put a washer behind it and reinstall the bracket. This would move the whole mount out to get you the clearance you may need!



If you have any problems with this, please call us for help at 407-834-5007!

LEG/WHEEL ASSEMBLY

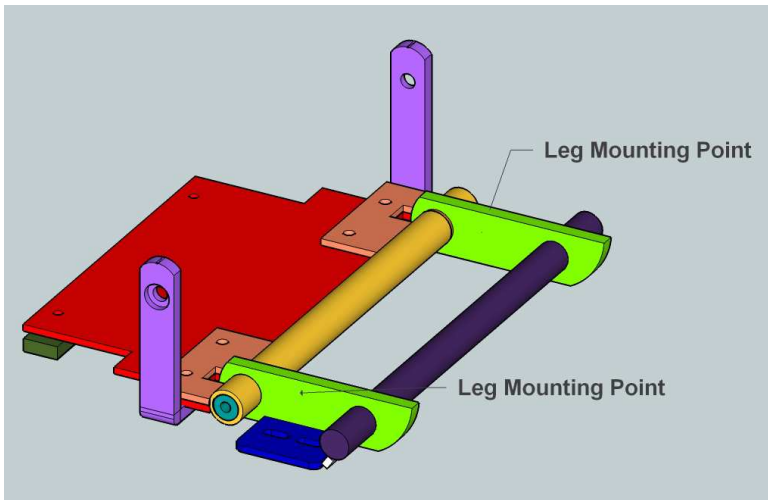

First remove the bolts from the stainless steel rod in preparation for mounting the legs. With help from an assistant, slide the Leg/Wheel Assembly around the rear tire (careful of the finish!), and align the Leg Mounting Points (green) with the slots in the Support Stand. If available a very small amount of 'Never Seize' on the shaft is in order here. Then start the stainless steel shaft in from one side through the tube on the support stand, and through the first leg mounting point

and its bushing. The fit is tight, so take your time. Carefully work the shaft through the tube and the second leg mounting point. The shaft is inserted properly when there it is inserted just past (approximately 1/8") the end of the tube. This distance should be about the same on both sides, but it is not critical as long as both sides are inside the tube. If you need to, you can tap lightly on the shaft (brass drift is preferred here). Once the shaft is in place, use a small amount of blue thread locker and install the (2) chrome bolts and washers on the end of the shaft to finish it off.

Make sure the legs move up and down without any binding!



MOUNT ACTUATOR

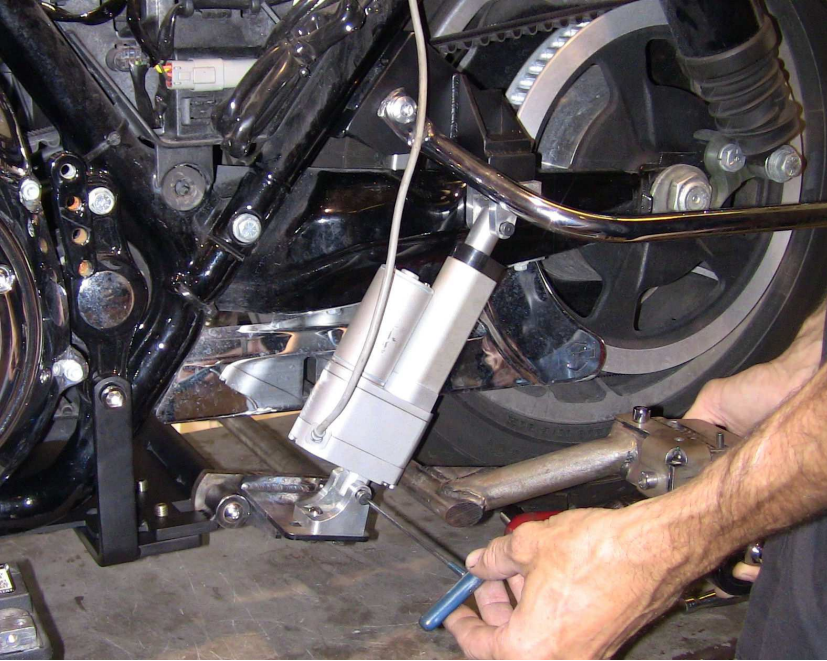

Remove the axles from both the upper and lower actuator mounts (if installed), and set them aside. Align the actuator, motor side (big end) down with the hole in the lower actuator mount, reinstall the axle, and start it threading into the mount. With someone supporting the wheel assembly, raise the legs until the top hole in the actuator is aligned with the upper actuator mount. You may need to enter maintenance mode to extend the actuator to get this aligned (see maintenance mode below). Install the axle in this mount as well (some wiggling may be required!).

At this point you need to make sure that the mounts are in alignment and the actuator is not in any sort of bind! If possible, snug up the actuator mounts in whatever position is the best with the actuator in its mounts. If needed, mark the mounts with a Sharpie, remove the actuator, tighten the mounts and reinstall the actuator. Make sure the axles slide in easily and there is no bind at all. Apply a drop of Blue Locktite to the threads of the axles before tightening them. **Make Sure** there is no bind or the actuator will fail prematurely! You may have to re-adjust these mounts after you install the exhaust!

You ultimately want the actuator to move the wheels as high as they can go. This usually means that the bottom actuator mount is adjusted for this affect. It doesn't matter at this moment, but you may need to do a final adjustment at the end of the install.

CONTROL SWITCH BOX

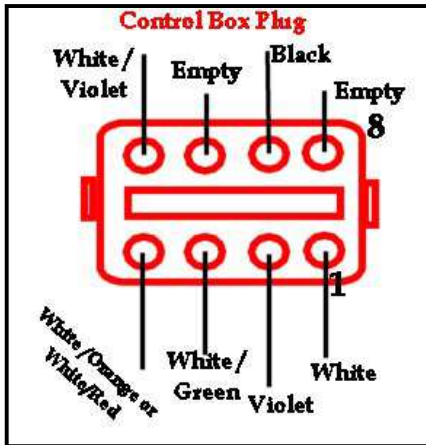

Remove the bolt on the top of the left switch housing. Find the long chrome bolt, thread it through the Control Switch Box, insert spacer on bolt and (with a drop of Blue Locktite), thread bolt into switch housing. Square the box before tightening the bolt (you may have to re-align the mirror for clearance). Route the wire inside the clutch lever and down the bar. Use wire ties to hold the wire to the bar. On Fairing bikes, route the wire into the fairing along the clutch cable and fish out the bottom left side of the fairing. On Windshield bikes, route the wire down the bar, and thread it into the Nacelle, fishing it out the bottom left side of the Nacelle (it may be easier to tape the silver plug ends

together for this). Once the wires are available at the bottom of the fairing or nacelle, thread the wires under the tank to end up under the seat area. On some bikes it is easier to loosen or remove some of the tank mounting bolts. Make sure the wires do not interfere with anything under the tank, and that there is nothing that would chafe the wires. Once the wires are under the seat area, you can assemble the plug according to Figure 6.



WIRING HARNESS

NOTE: If you have a LITE System, Please refer to the addendum at the end of this manual, for differences between a Regular and LITE Harness!

The next step is to route the wiring harness. The harness and the plugs are routed mostly under the left side cover. Different models have different amounts of space in this area, and all the wires are long enough to allow you to place the connectors in the best place for your bike. What you need to do is get the eight pin plug and the double white plug from the harness to the area under the seat. The large 12 place plug attaches to the Computer Enclosure, and that plug needs to land near the left saddlebag. The plug from the

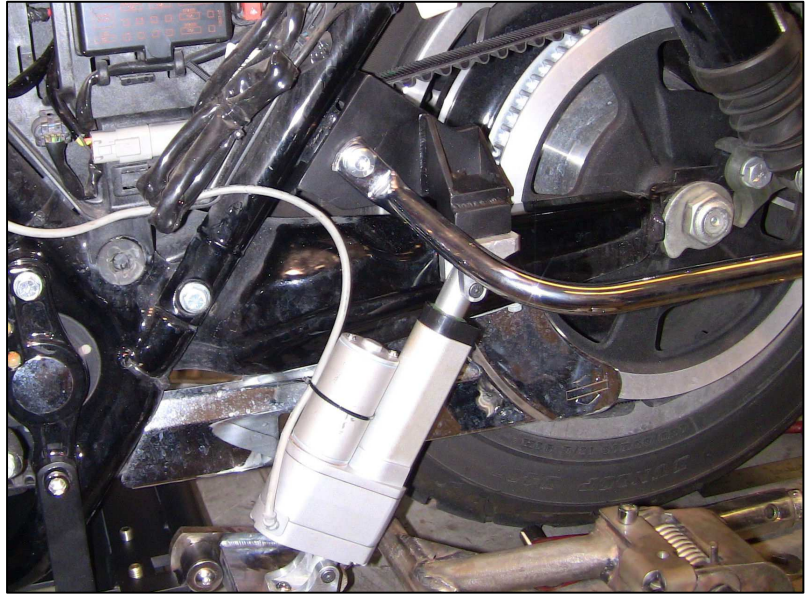

Actuator (5-wire) and the plug from the Proximity Sensor (3-wire) need to route in the side cover area to meet their corresponding plugs. At this point just route the wires into the general area and plan where you would like to tie them up safely. The Proximity sensor is not mounted yet because we need to have power to make sure it is placed perfectly, so just route the wire for now. You can collect any excess wire under the side cover when the time comes.

Connect the Control Switch Box plug to its mating connector under the seat, and plug the actuator and proximity sensor plugs to their matching connectors.

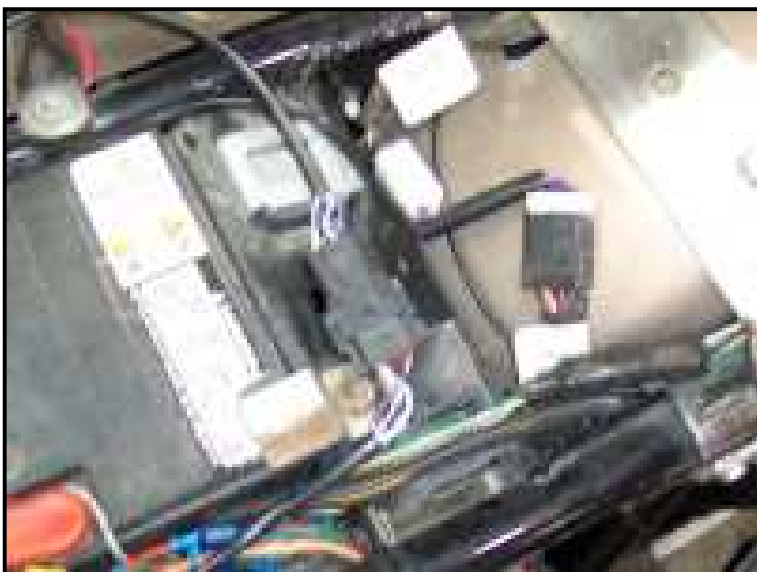

Next we need to connect to a power source. On 2009 models, Disconnect the fender plug under the seat, and plug the double white plug in-between the plugs from the bike. On 2010 and later bikes, the fender plug is not like the one shown here, so we plug into the accessory connector instead. The picture on the next page shows this connector, under the seat below the ECM. Remove the rubber plug and plug the four pin (with just two wire; orange/black) into the bikes' accessory connector.

Next plug the computer enclosure plug in its mating connector as well. Lay the enclosure on the lift or support it somewhere... Don't dangle it by its cord! Don't worry, the plugs only work one way... you can't make a mistake here!



Don't tie down the wires just yet but if you have all the plugs connected, we can do a quick test of the system. There are 2 things we want to check here. We want to make sure the controls work, and we want to check the light on the proximity sensor is functioning.

Illustration: Accessory Connector under the Seat.

INITIAL SYSTEM TEST

NOTE: If you have a LITE System, Please refer to the addendum at the end of this manual, for differences between a Regular and LITE system. Skip this section if you have a LITE System.

Turn your bike to ***Accessory Mode***. Counter clockwise on Road Kings and dash mounted switches or all the way clockwise on Electra Glide bikes. Typically your speedometer or tachometer will illuminate as well as your rear fender light. At this point, have a look at the yellow proximity sensor. The LED Should Not Be Lit. Take a metal object (screwdriver, wrench, etc) and hold it on the flat face of the sensor (it has a circle embossed in it). The LED should light up, and go out when you move the metal away. If not, check all your connections.

Next, press the rightmost pushbutton and hold it for at least 3 seconds. One or both LEDs on the switch panel should light up; we really don't care which at this point. If this occurs, you are doing well. If both LEDs are flashing (maintenance mode) you can skip the next step which is to press both buttons until both LEDs flash.

Next press both buttons for just an instant! If everything is working, the bottom or yellow LED on the switch box should flash, and the top LED should be out. The next step, and be careful here, is to touch the left button for a split second. The legs should move down just a bit. Touch the right button, and they should move up. With the bike on the lift, ***you have to be very careful here!***

If all of the above has occurred, raise the legs. Press and hold the right button until it stops, and turn the ignition switch off!

The test is now complete. Let's move on to mounting the Proximity Sensor.

MOUNT PROXIMITY SWITCH

NOTE: *If you have a LITE System, Please refer to the addendum at the end of this manual, for differences between a Regular and LITE system. Skip this section if you have a LITE System.*

This step is crucial!! Understand it before starting. The proximity sensor tells the system how fast the bike is traveling. The proximity sensor mounts to the lower shock bolt on the right side of the bike. You need to jack up the rear wheel so we can spin it to test the sensor and its placement. Make sure the bike is in neutral.

With the bike on the lift, the rear wheel off the lift and the bike in Neutral, remove the bottom bolt from the right shock at the rear of the bike. Insert the 'U' shaped bracket with the proximity sensor attached, behind the shock and in front of the hole in the swing-arm, so the bolt will pass through it when reinserted.



Reinsert the shock bolt and tighten the nut just a bit, so the bracket can move freely, but snug enough so it stays where you put it.



Find the angle for the bracket that will allow the rotor bolts on the brake rotor to pass by the proximity sensor in the middle of the square portion of the sensor. When you think you have it, turn the ignition to Accessory position, and roll the wheel to make the bolts pass by the sensor. Each time one passes the sensor, the LED on the sensor should go bright then off.

If this is not happening, you may need to get the sensor a bit closer to the pulley bolts (5MM is a very small distance!). If you have to move the sensor closer, you may have to shim the back of the bracket or bend it just a tad. No matter what you need to do, you **MUST** make sure that as the wheel turns, the light works as described above! Once you are certain, tighten the shock bolt and test it again! Rotate the wheel past all 5 rotor bolts and make sure the light blinks and goes out each time. If all is perfect, you are done! The automatic retraction of the legs as well as their deployment **RELIES** on this sensor being placed perfectly! Now we can route the wire.

WIRE ROUTING

NOTE: If you have a LITE System, Please refer to the addendum at the end of this manual, for differences between a Regular and LITE system. The Proximity sensor is NOT part of the LITE system!

Detach the Sensor from its mating plug to allow you to permanently route its wires. Run the wire on top of the swing arm, using the self-adhesive clips provided. (See picture wire route in RED), then up under the seat and across and down to the left-side cover area to its' mating plug.

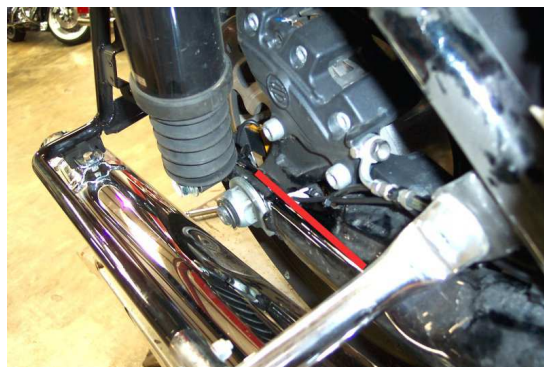

Unplug the Computer Enclosure from the harness, and using the Velcro, attach the enclosure with the wires facing the right (as viewed from the rear). Once the enclosure is attached, make a small groove in the bag that the wire can fit into without being crushed, and route the wire outside the bag. Use a small file, Dremel tool, or a bur to make this slot. Make sure it reaches its, mating plug, and that the plug will not rub on anything if the enclosure is disconnected. Also make sure that is reasonably easy to plug and unplug this connector with the bag loose. We suggest leaving the plug connection inside the bag, but it can be left outside as it is waterproof.

Use wire ties to make sure that all wires will stay where you put them and that they will not come on contact with the belt or anything else that moves.

While you still have the bike raised, turn on the LegUp system (see owners manual). It should start in maintenance mode, but if it doesn't, please enter maintenance mode (again in the manual). Now carefully, lower and raise the legs and make sure the wires are not binding and that they clear everything! Raise the legs most of the way and turn off the bike. Now we are ready to button everything up.

FINISHING UP

Now it is time to reinstall the exhaust, and do final checking of everything! Carefully reinstall the exhaust system. When reinstalling the mufflers, be careful that the wheels clear them! You may need to turn on the system and use maintenance mode to test this. If there is a clearance problem as you install the mufflers, you may have to rotate them just a small amount, to get the clearance you need. Also check that the clamps are not binding on the mechanism as you lower and raise the legs. Sometimes a different clamp may be needed for a heat-shield or muffler to allow the clearance required. LegUp has Low-profile, stainless clamps if needed.

This would be a good time to check that the actuator brackets are adjusted properly; both for up and down motion (you would like the actuator to stop at its uppermost point if you can) and side to side to avoid binding.

Reinstall the side cover and the bags; making sure that everything is clear. We recommend using maintenance mode to get the legs up high but still below the bags. Turn off the ignition switch when complete so as not to have the computer set it's up and down settings until later. Reinstall the seat making sure all your wires are routed neatly, tied off nicely and don't interfere with the seat installation.

As noted earlier, if you are installing the system on an FLHX, you MUST invert the rear peg mounts, or remove them to clear the actuator. This may have become obvious by now. Flip the pegs over in their mounts, then mount the brackets upside down in the highest hole available, and you are done. The passenger will still be comfortable and you will get the clearance you need.

Once you are comfortable that everything is correct, double-check all your bolts for tightness, and get the bike off the lift so you can dial in the actuator, and adjust the wheels.

ACTUATOR ADJUSTMENT (Maintenance Mode)

NOTE: If you have a LITE System, Please refer to the addendum at the end of this manual, for differences between a Regular and LITE system. Skip this section if you have a LITE System.

Once you have the bike on the ground, turn the ignition to the accessory position and start the LegUp System (hold right button for 3 seconds). The system should enter maintenance mode automatically (Both LEDs Flash), but if it does not, enter maintenance mode manually (Both buttons for 3 seconds). With a helper nearby, straddle the bike, and hold it level. Hit both buttons for an instant to get the system in the "DOWN" setting mode (yellow LED flashing). Straddle the bike so your weight is NOT on the seat, hit and hold the left button until the wheels

contact the ground and stop. Make sure that the suspension raises a bit as you do this. If not, the legs are not going down far enough, the bottom actuator mount may need to be moved left or right a bit to get the wheels all the way down (Contact LegUp for assistance if you need help with this). Once these wheels are down as described above, try to put both feet on the floorboards. The bike should be reasonably stable and you should be able to lean a bit in both directions without the bike falling over. The DOWN stop is now set!

Hit both buttons for a moment to get into the “UP” stop mode (top LED blinking).

Carefully use the right button to raise the legs. Have your helper let you know as you approach anything that may come in contact with the wheels or the legs. You also need to make sure the system clears pipes, clamps etc. If you can't make the clearance to allow the legs to come up all the way, you can set the up stop just below whatever is interfering (if not, you will likely set up a permanent rattle!) Hit both buttons when complete, and you will be done with these adjustment.

Now press the left button and the legs should lower. Hit it again and the legs should retract. If you are satisfied with these limits, you have successfully installed the LegUp System. Time for a test ride!

TEST RIDE

NOTE: If you have a LITE System, Please refer to the addendum at the end of this manual, for differences between a Regular and LITE system. Deployment and Retraction of the wheels is COMPLETELY MANUAL if you have a LITE System.

Get the bike to a clear paved mostly level area where you can test ride it. Start the bike, turn on the LegUp system and lower the legs. The first test should be done in a straight line. Put the bike in gear and slowly accelerate. You may notice that the bike tends to want to steer a small amount left or right. This is normal unless it is severe. Once underway, the top LED should flash at around 6 MPH, meaning the legs are retracting. You can lean on one wheel or the other as you leave to reduce any darting the system may be giving you.

Assuming the legs are retracted, you should try to deploy the wheels. As you come to a stop, the Green LED should be on. As you slow down (**almost stopped**), the Yellow LED should illuminate at the proper speed. Once it does (sometimes hard to see), hit the left button and put your feet down near the ground. The top LED should flash and you should soon feel the wheels deploying underneath you! Make sure you are ready to balance the bike! Uneven ground or lack of familiarity could make the bike want to lean one way or the other. With your feet ready to balance the bike, this should be no big deal. The slower you are going when deploying the wheels, the smoother the transition will be from wheels up to wheels down. Practice these maneuvers until you are comfortable with the wheel adjustments and the system operation.

SEMI-AUTOMATIC DEPLOYMENT: Another way to deploy the legs is to hit the left button while you are running at any speed over 10MPH with the wheels up. The bottom or yellow LED should start to flash. When you slow down to around 8MPH the wheels will start to deploy (see the red/green flash on top LED). Again prepare to put your feet down.

The next thing to try is to make a turn right after a dead stop with the wheels down. As soon as you start the bike moving, try a left or right turn immediately by leaning into that turn. You may find that you have to nudge the bike a little bit more than usual to get the bike to lean, and you won't be able to lean as far as you can with the wheels up. Once into the turn, accelerating will raise the wheels. You will hardly notice the wheels coming up unless you see the top LED blinking!

The next thing to try is slow speed maneuvering with the wheels lowered. In a straight line on level ground, you should be able to keep your feet on the floorboards and move the bike forward at very slow speeds (simulate stop and go traffic). I like keeping my feet near the ground during these maneuvers! You can also try small 'Trike' turns; keeping the bike upright at slow speed and making turns as you would in a parking lot. Be aware that if you get over the speed that the legs come up, they will!!! Another thing I like to do is donuts. Start out slow, lean the bike left or right, and make circles at very slow speeds (throttle on, rear brake on,

clutch slipping... you know like the cops do!). This helps you get familiar with the wheels being on the springs and allowing a lean angle!

Practice, practice, practice!! Enjoy your LegUp System!

LEGUP LITE - ADDENDUM

If you have a Lite System, there are a few differences in the wiring compared to our Regular system.

The plugs and their locations don't change at all! Instead of plugging in the computer to the twelve pin plug, the Relay-Pack gets plugged into this plug. The Relay-Pack will be attached with Velcro as the computer would have been in the same location.

On the LITE system there is no proximity sensor, so ignore the testing and mounting of this sensor, and realize that the three pin plug will be left without a mating connector. We keep this plug in the wiring harness in case you upgrade to a regular system in the future.

Using Your Lite System:

Unlike our Regular System, you don't turn the **LITE** system on, or adjust the legs as described in the '**Maintenance Mode**' section of the manual. When you turn your bike on, the LITE system is ready to go! Press and hold the left button to lower the wheels, press and hold the right button to raise them. No lights will flash; it is up to you to control the system manually!

Please use EXTREME Caution when using the LITE System! Keeping the wheels lowered at speeds over 9MPH can be dangerous. Since the system is manual, please don't allow its' operation to distract you from controlling the vehicle!

Upgrading Your LITE System:

If you have a LITE System and have chosen to upgrade it to the regular system, there are just a few things you need to do. Unplug the Relay-Pack, and plug the computer in where the Relay-Pack was attached. Run the wire for the proximity bracket and plug it in, test it, and mount it, as described in the '**MOUNT PROXIMITY SWITCH**' section of this manual.

Once the new pieces are attached and plugged in, refer to '**ACTUATOR ADJUSTMENT (Maintenance Mode)**', earlier in this manual to set the lower and upper stops for the computer.

That's all it takes!

ILLUSTRATIONS

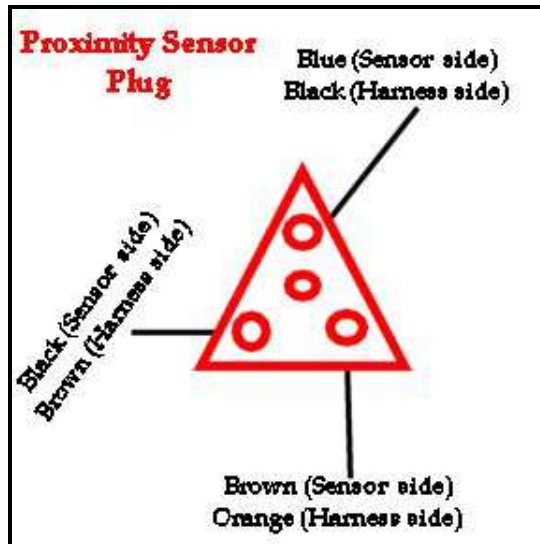

Wiring 1

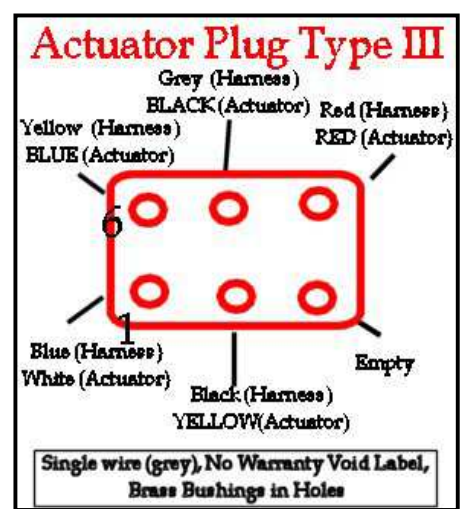
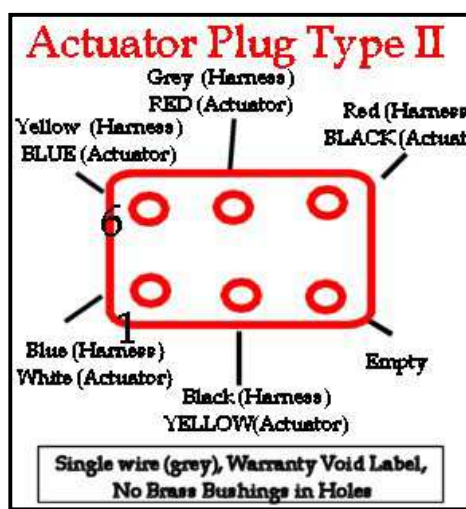
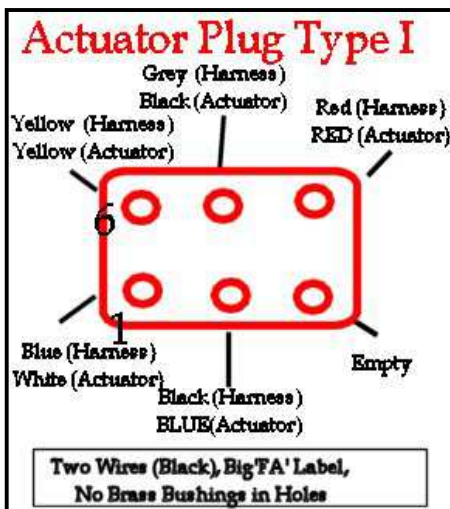

There are three different types of actuators with three different wiring configurations. Refer to the notes at the bottom of the pictures above so you can match your actuator with its wiring scheme!

Wiring 2

12 Place Enclosure Plug

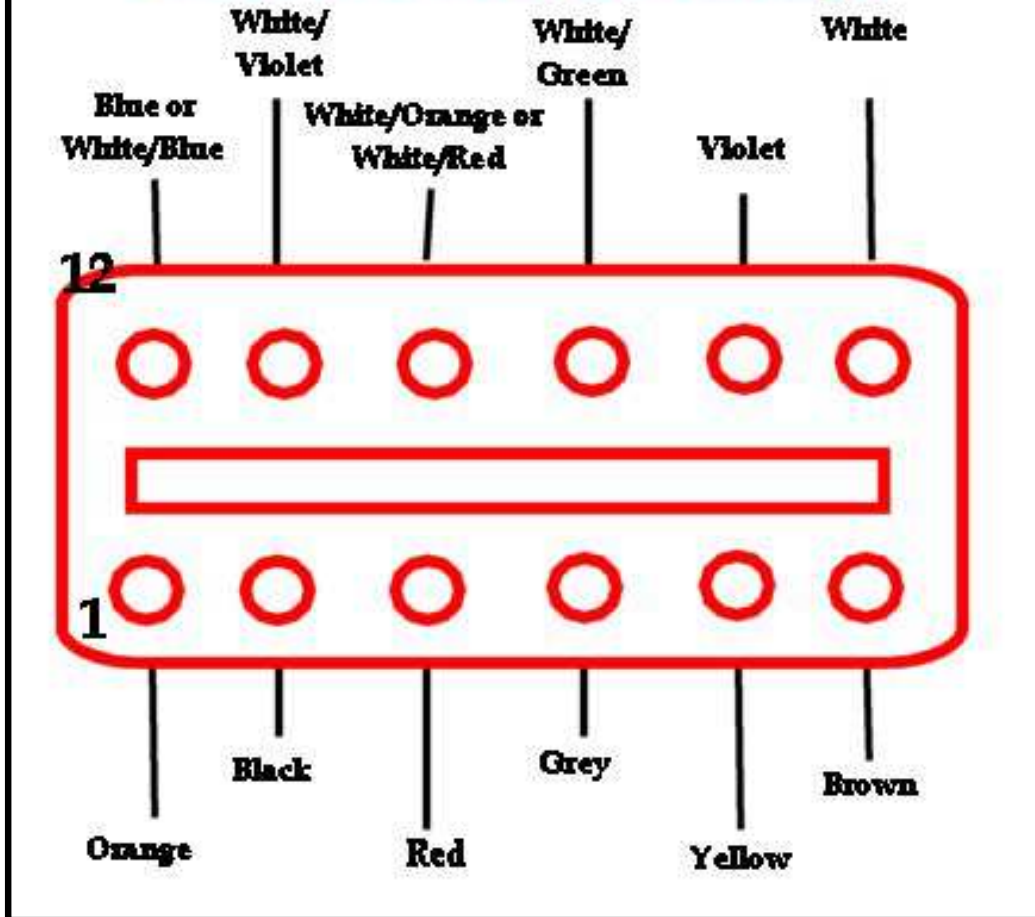

Wiring 3

Parts List

- (4) 3/8-16 X 1" Cad Bolt with Split Washers
- (2) 5/16-18 X 1" Cad Bolt w Split & Flat Washer
- (2) 5/16-18 X 1/2" Cad Bolt w Split Washer
- (1) 7/16-14 X 1" Chrome Allen (Right Side Upright)
- (1) 7/16-14 X 1 1/2" Chrome Allen (Left Side Upright)
- (1) 7/16-14 X 1 1/2" Chrome Allen with Acorn Nut
- (2) 5/8" X 3/8" X 1/4" Chrome Spacers (ID 3/8")

Wire Ties & Self Adhesive Straps